

# Installation and Operating Manual

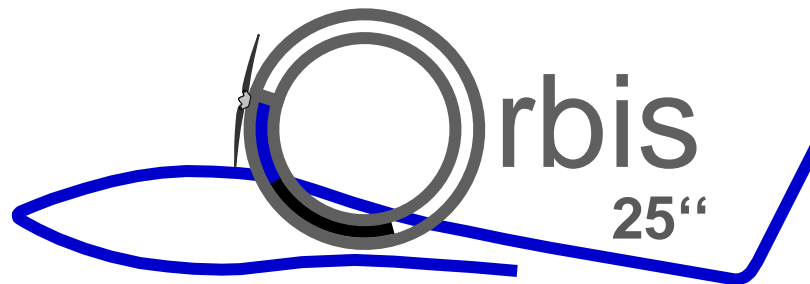

**for the ORBIS 25''  
self-launch-system**

**2023 / 06**

[www.dr-martin-thoma.com](http://www.dr-martin-thoma.com)

# Content

Preface to this installation and operating manual .....	3
1. Installation instruction .....	4
1.1. Legend.....	4
1.2. Verify spatial requirements .....	6
1.3. Determining the distance l .....	6
1.4. Cut-back of the rear wing spar.....	6
1.5. Cast for a fuselage cover.....	7
1.6. Cut out the fuselage hatches .....	7
1.7. Fuselage hatch hinges.....	8
1.8. Limit stop for the fuselage hatches .....	9
1.9. Hooks for the flap springs .....	9
1.10. Birch plywood support for the aluminium-support-frame .....	10
1.11. Installation of the energy chain .....	12
1.12. Cabling for operation .....	12
1.13. Installation of the brushless motor .....	13
1.14. Mounting of the prop mechanism .....	13
1.15. Installation of a fuselage cover .....	13
1.16. Installation of springs and a piece of wood on the left fuselage hatch .....	14
1.17. Installation of a wheel cover .....	15
2. Warnings .....	16
2.1. General Attention.....	16
2.2. Warnings and safety instructions.....	16
2.3. Disclaim of liability and damage.....	18
3. Programming and Operation .....	19
3.1. Introduction to the programming .....	19
3.2. Programming of the radio transmitter .....	19
3.3. Programming of the receiver .....	20
3.4. Installation and adjustment of the MASTER SPIN 170 OPTO controller .....	20
3.5. Introduction to the Dirk Merbold controller .....	22
3.6. Programming of the Dirk Merbold controller .....	22
3.7. Operation procedure.....	25
3.8. During operation: avoiding overheating of the motor .....	28
4. Maintenance .....	29
4.1. Prop mechanism and motor bell .....	29
4.2. Self-launch-system .....	31
5. Warranty .....	32

# Preface to this installation and operating manual

This manual must be read carefully before installing or operating the self-launch-system ORBIS 25. The chapters will cover the following topics:

1. **Installation:** The first chapter takes you through the installation step by step and describes how to cut the fuselage opening and the install the fuselage covers, where to position the support-frames.
2. **Warnings:** Read the warnings carefully before operating the ORBIS 25. Do not forget that you are operating propeller blades with up to 4.200 Watts!
3. **Programming and Operating Instructions:** The programming of the Dirk Merbold Controller and the operating of the ORBIS 25.

**Important note for receiving systems: Set the receiver's output period to 20ms.** Modern receivers allow a shorter output period than 20ms. Unfortunately, the Merbold control can't convert the receiver signals correctly if the output period is less than 18ms. Please set the receiver's output period to 20ms.

To prevent the motor from **overheating**, only interval operation of the ORBIS is permitted (see Section 3.8.)

4. **Maintenance:** Necessary maintenance work on the ORBIS 25.
5. **Warranty:** The document ends with the warranty conditions.

Please pay special attention to the text marked with the following symbols:



**Important warnings and information for operation security**



**Important information**

Please send us your comments or suggestions for improvement of this manual or the ORBIS 25 to:

[info@dr-martin-thoma.com](mailto:info@dr-martin-thoma.com)

Your helpful suggestions have lead to this improved version of the ORBIS 25!

# 1. Installation instruction

## 1.1. Legend

The figure below shows the different components of the ORBIS 25 self-launch-system. This installation instruction refers to these components.

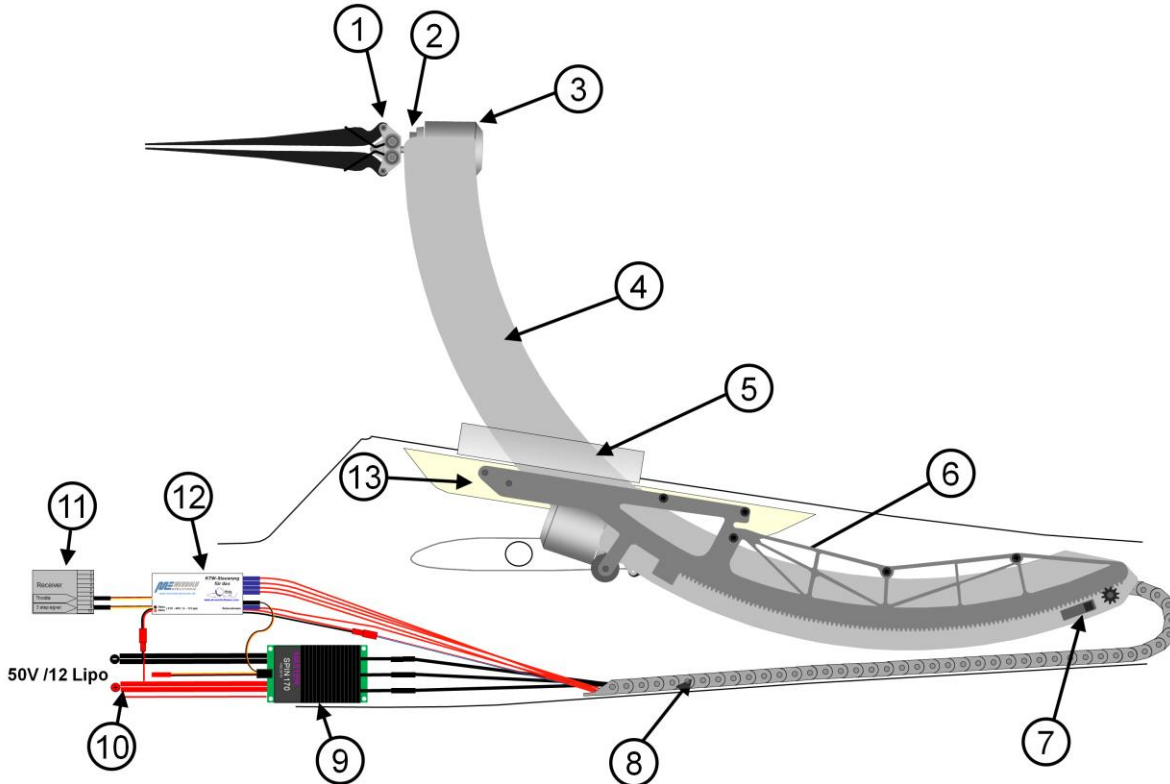

Graphic 1.1.1 Legend for the ORBIS 25 overview

1. Prop mechanism.
2. Tilt plate.
3. Brushless motor.
4. Full carbon-ORBIS-support arms
5. Fuselage cover
6. Aluminium-support-frame.
7. Micro switches to control the extension and retraction.
8. Energy chain.
9. Brushless controller MASTER SPIN 170 OPTO
10. Power supply for the brushless controller MASTER SPIN 170 OPTO and for the gear motor via the Dirk Merbold controller.
11. RC-receiver.
12. Dirk Merbold controller.
13. Birch ply-wood support.

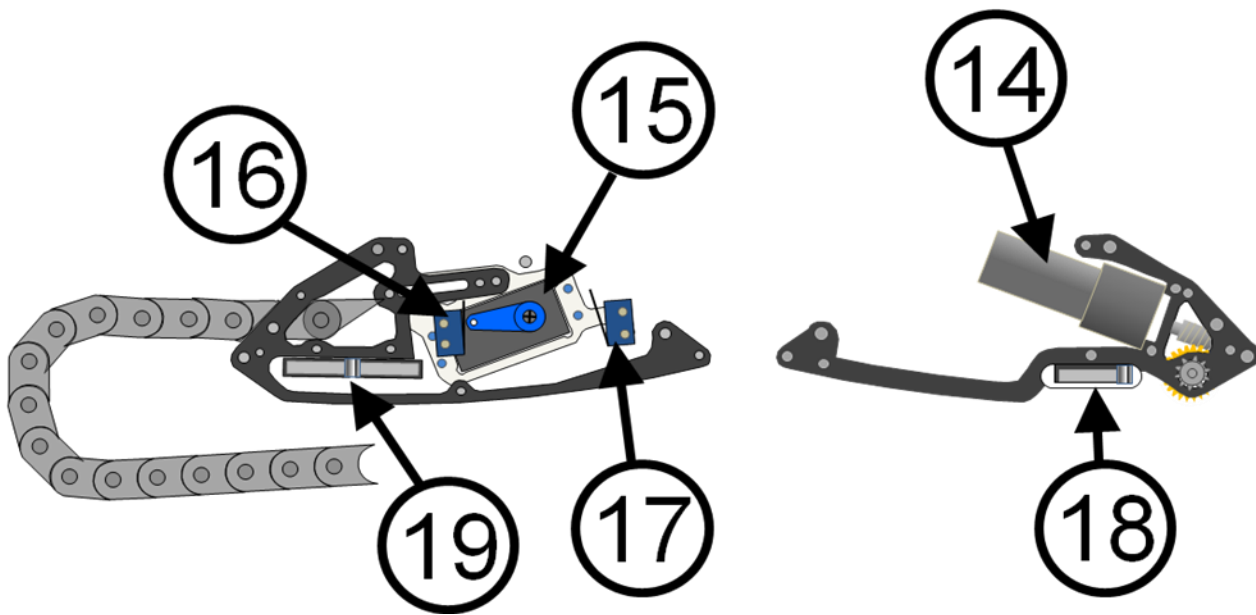

Graphic 1.1.2 Legend for the lower ORBIS 25 area

- 14. Gearmotor.
- 15. Turning- servo.
- 16. Micro switch for safety function: Important to prevent motor starting inside the fuselage.  
The micro switch will be activated only when the ORBIS 25 is completely extracted and the tilt-servo / prop mechanism is in flight position.  
Connected via female connector 8 on the Dirk Merbold controller.
- 17. Micro switch for the retraction activation of the gear motor.  
Connected via female connector 7 on the Dirk Merbold controller.
- 18. Micro switch for the extension deactivation of the gear motor.  
Connected via plug 6 on the Dirk Merbold controller.
- 19. Micro switch for the retraction deactivation of the gear motor.  
Connected via female connector 5 on the Dirk Merbold controller.  
Aside is a second micro switch to cut-off the power supply of the tilt-servo when the ORBIS 25 is fully retracted.

## 1.2. Verify spatial requirements

Before you begin with the installation you have to verify the spatial requirements of the ORBIS 25. In a distance of 730-930 mm from the rear edge of the cockpit canopy the diameter of the fuselage must be at least 145 mm ( see graphic 1.2.1 ). Insert the ORBIS 25 into the fuselage to verify if you have enough room.

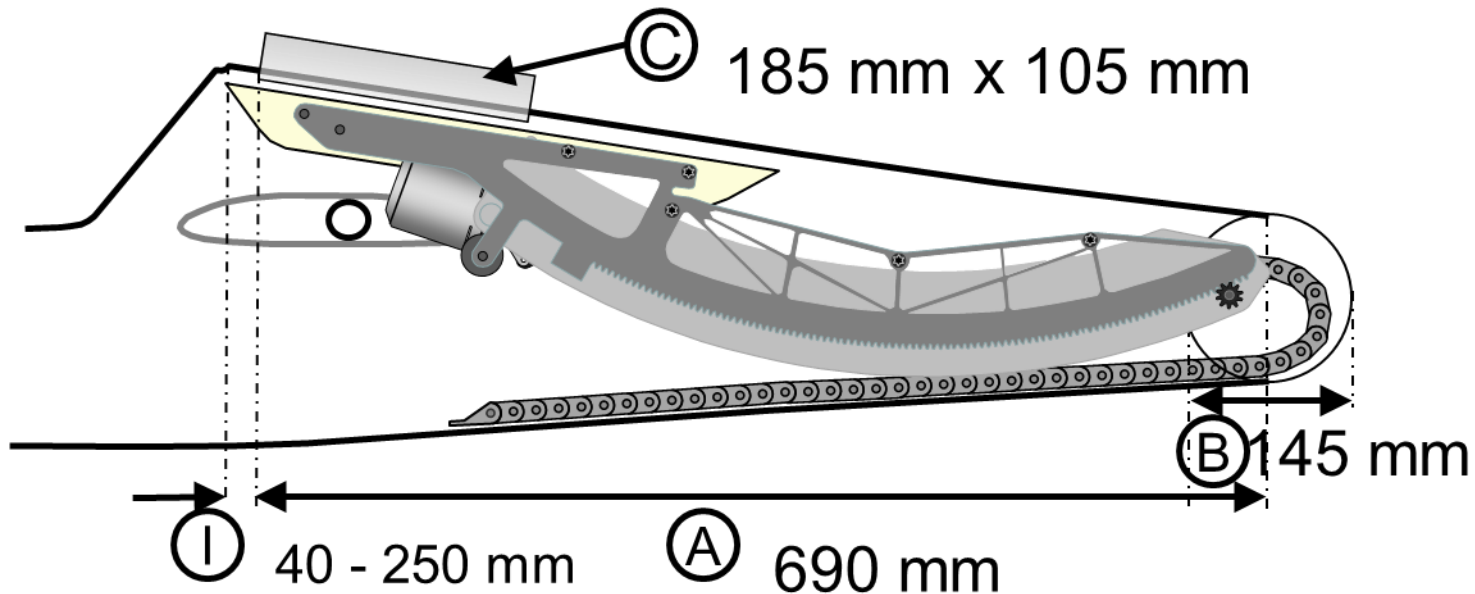

Graphic 1.2.1 Spatial requirements for the ORBIS 25

## 1.3. Determining the distance I

The distance from the rear edge of the cockpit canopy to the front edge of the fuselage opening ( see graphic 1.2.1.-distance I) should be between 40 mm and 250 mm. With a very narrow fuselage this distance may have to be diminished down to 10 mm. When you have determined the value for the distance I, double-check the spatial requirements.

## 1.4. Cut-back of the rear wing spar

Because of spatial requirements the rear wing spar has to be cut-back centric over a length of 110 mm. The remaining wing spars have to be reinforced with a glass fibre epoxy resin.

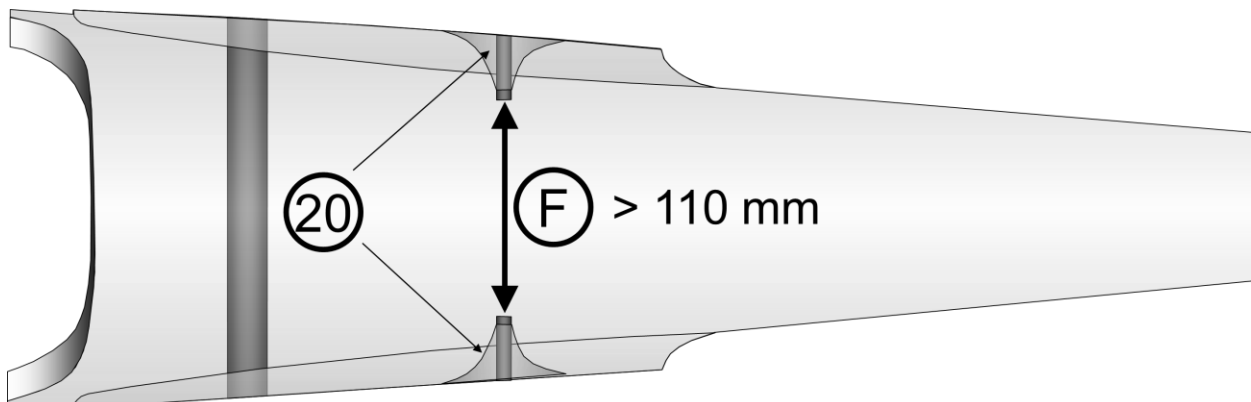

Graphic 1.4.1 Cut-back of the rear wing spar

### 1.5. Cast for a fuselage cover

One special feature of the ORBIS 25 is that you can attach a cover between the two carbon arm supports, which covers the fuselage opening in the extended position. To make this fuselage cover you must make a cast in the range of the fuselage flaps. Please make a second cover for replacement. Put a thin plastic foil over the fuselage and laminate at least four to five glass and carbon fibre layers with epoxy resin in the minimum size of J 185 mm x H 105 mm.

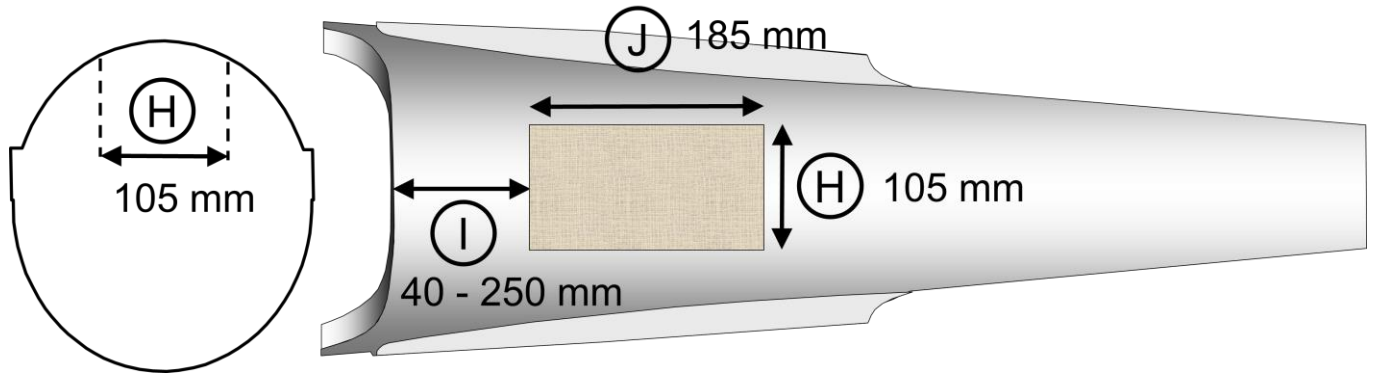

Graphic 1.5.1 Cast for a fuselage cover

### 1.6. Cut out the fuselage hatches

Mark the cut-out for the two fuselage hatches with a pencil. The hatches are divided along the centre of the fuselage. Please keep in mind that the upper fuselage joint does not necessarily represent the actual centre of the fuselage. Measure the two fuselage hatches according to graphic 1.6.1, where the length of the fuselage hatches J is 185 mm and the width H is 105 mm. **The fuselage opening must have a width of 105 mm.** Since the hatches are curved, they have a slightly larger width. Measure the width from the top with a calliper gauge. Cut out the fuselage hatches with an **oscillating 0,4 mm saw** or second best take a sharp knife or a Dremel using a thin cutting wheel. Use straight metal rail guidance and fasten it with screw clamps.

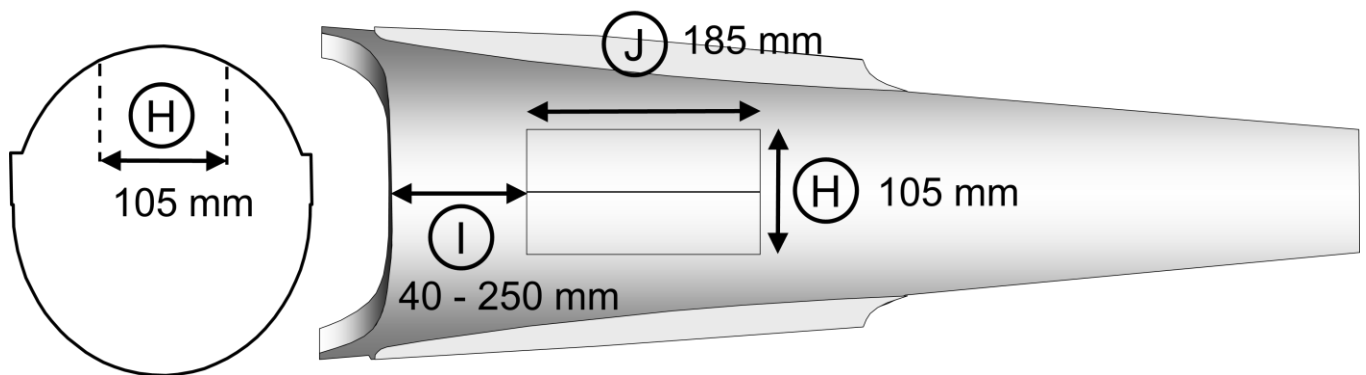

Graphic 1.6.1 Cut out the fuselage hatches

## 1.7. Fuselage hatch hinges

Attach four brass tubes with a length of 20 mm (2.0 mm outer diameter / 1.1 mm inside diameter ) with superglue on the inside of the fuselage flaps as shown in the figure below.



**Do not use larger tubes! Otherwise the ORBIS 25 cannot extend through the opening!**

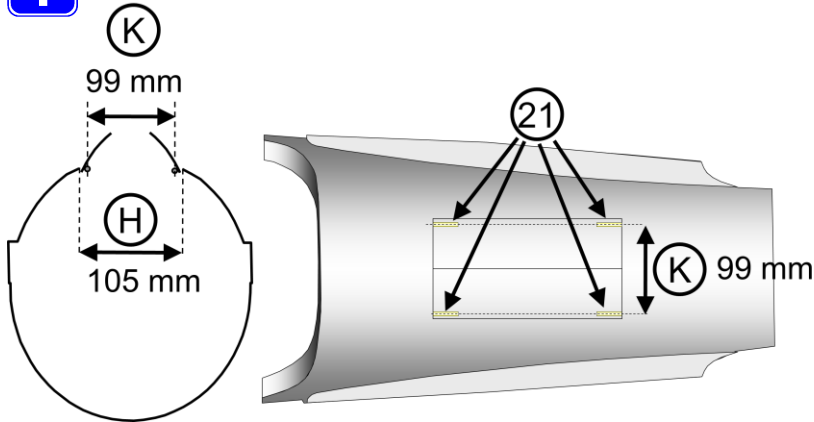

*Graphic 1.7.1 Attachment of fuselage hatch hinges*

Then a 1 mm spring steel wire of 35 mm length is glued into both front brass tubes with superglue. (see graphic 1.7.2 - 22).



*Graphic 1.7.2 Attachment of spring steel wire*

Four brass tubes ( 2,0 mm / 1,1 mm ) ( see graphic 1.7.3 -23 ) with a length of 20 mm are mounted inside the fuselage with superglue. It is recommended to attach both flaps with PVC tape before gluing in order to adjust the position. The curved spring steel wires in the rear brass tubes have to be removable but must not slip out of the tube. Therefore the steel wire should be broadened a bit with a hammer so that it jams in the brass tube of the flap.

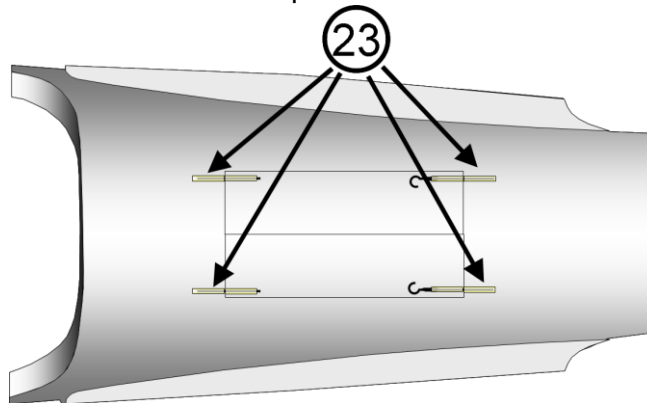

*Graphic 1.7.3 Attachment of brass tubes*

After attaching the brass tubes with superglue take epoxy resin and glass fibre in order attach everything firmly.



### 1.8. Limit stop for the fuselage hatches

In order to have a limit stop for the fuselage hatches you attach a glass fibre plate on the inside of the fuselage.

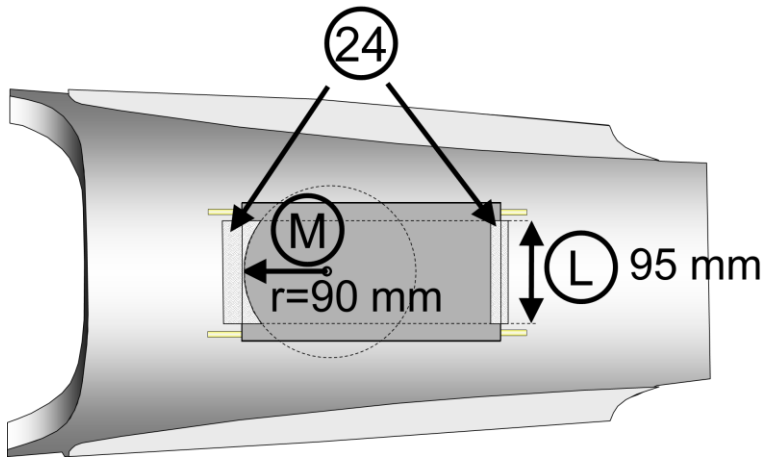

Graphic 1.8.1 1.8. Attachment of limit stop for the fuselage hatches

After attaching the limit stops with superglue take epoxy resin and glass fibre in order attach everything firmly.

### 1.9. Hooks for the flap springs

A hook is needed on each hatch to attach two springs that close the flaps in the retracted position. Attach with epoxy resin and fibre material the two metal hooks out of 1.5 mm spring steel wire on the fuselage hatches. It is advisable to bend the lower end around to increase the adhesive surface. Make these hooks very flat, so that the motor cables do not get entangled in the hooks.

Thus jamming the flaps when opening, the attachment of a gap cover with super glue and then with epoxy is recommended (see chart 1.8.1 -26). This is especially necessary if the trunk flap is made of a softer material. Otherwise, the body flaps could bend up slightly during the opening and get stuck.

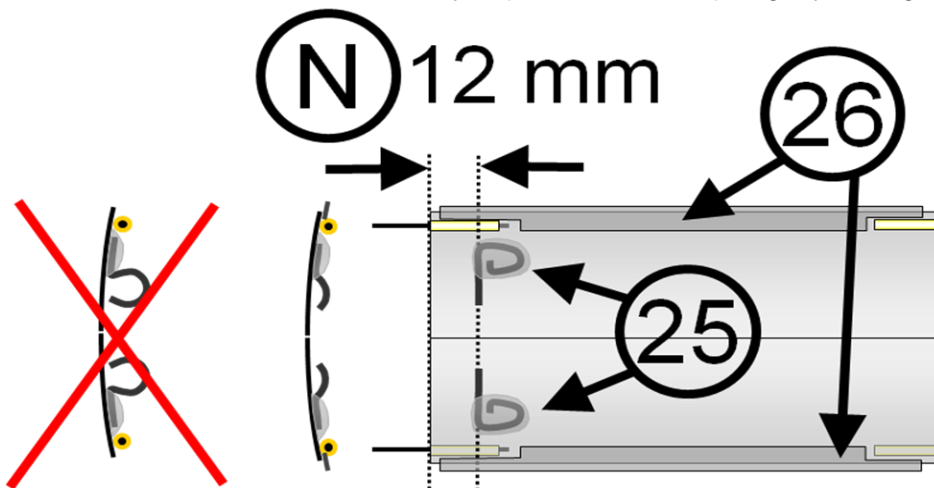

Graphic 1.9.1 Attachment of the hooks for the flap springs

## 1.10. Birch plywood support for the aluminium-support-frame

Two 6 mm thick front birch plywood supports for the aluminium support frame are now adapted according to graphic 1.10.1. It is recommended to adjust a cardboard piece first in order to find the right fuselage form for the upper edge. The upper edge must be inclined in order to become gap free to the fuselage (see graphic 1.10.3 ). Attach a 20 mm M2 screw into both plywood supports from below (see graphic 1.10.1 - 28) and screw it in for 10 mm. Cut off the head. This screw will later on hold the spring for the flaps.

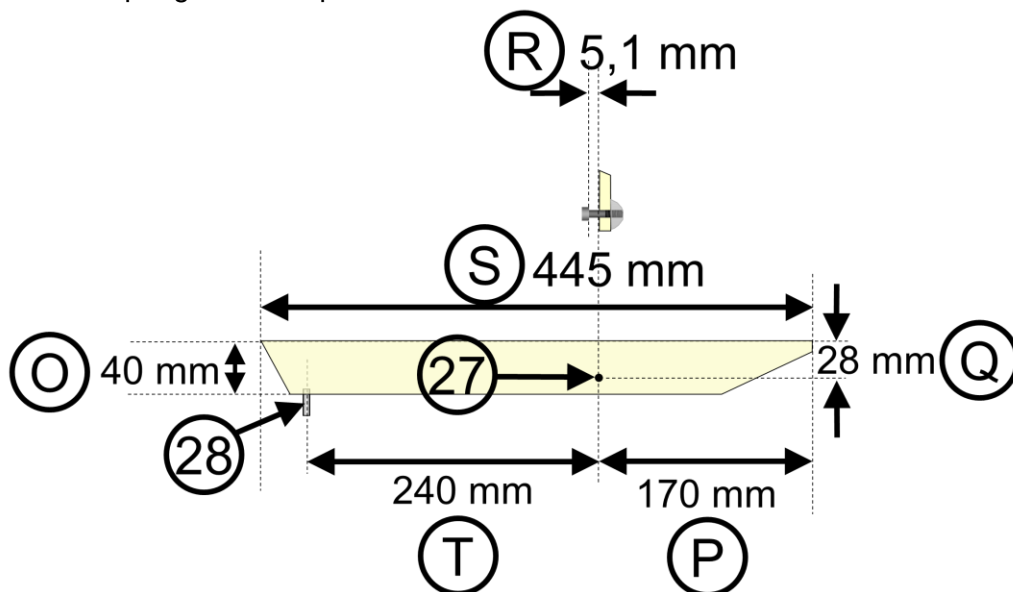

Graphic 1.10.1 Cutting out the left birch plywood support for the aluminium-support-frame

In addition to the two longitudinal birch plywood support, a semicircular cross support has to be adapted to the top of the fuselage. The side supports must be able to support themselves on this cross support in a corresponding cutout (see graphic 1.10.2 ).



Graphic 1.10.2 Birch plywood support frame for ORBIS 25

At the marked position 27 (see graphic 1.10.1 - 27) a 4 mm hole is drilled and the delivered M4 cylinder head screw is inserted and well attached with epoxy resin and fibre material. Between the plywood support and the cylinder head a distance of 5,1 mm must remain ( see graphic 1.10.1 – R ) so that the aluminium-support-frame can be inserted.

Push the aluminium-support-frame via the canopy opening into the fuselage. The back part of the aluminium-support-frame should have only a few millimetres of distance between the upper fuselages border (see graphic 1.10.3 -29).

**i** The rear edge of the full carbon-ORBIS-support arms must have a distance of 2 mm ( 1.10.3 - U) between the rear edge of the fuselage opening. Not more and not less.

In the front section of the aluminium-support-frame are two holes for the attachment of with two M4 imbus screws (see graphic 1.10.3 -29). Adjust the aluminium-support-frame in the desired position and mark the spot 29 on both plywood supports.

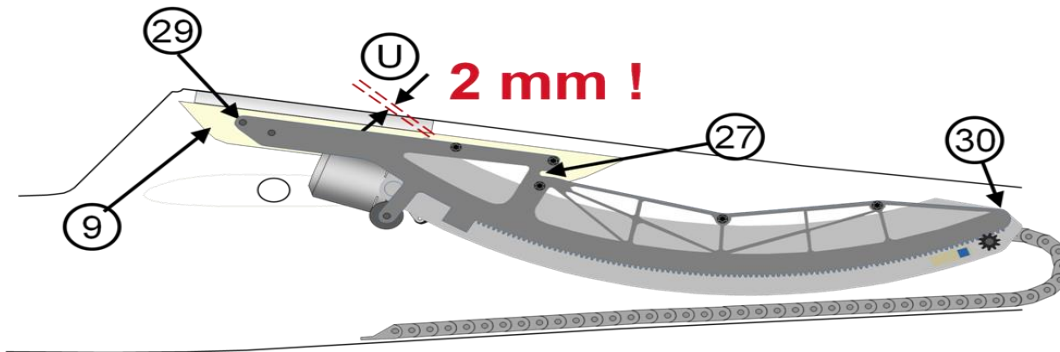

Graphic 1.10.3 Adjustment of the installation position of the ORBIS 25

Drill a 6 mm hole on the position 29. Insert a drive-in M4 nut into the plywood supports. Attach the aluminium-support-frame onto the plywood supports by screwing in the M4 imbus screws. Turn the fuselage upside down and carefully adjust the desired position. Make sure that the fuselage opening is at the correct position so that the ORBIS 25 can extract out of this opening. Attach the plywood supports with thickened (thixotroped) epoxy resin and fibre material on the grinded fuselage side ( see graphic 1.10.4 -31). The M4 cylinder head screws (see graphic 1.10.3 - 27) are also well attached with epoxy resin and fibre material.

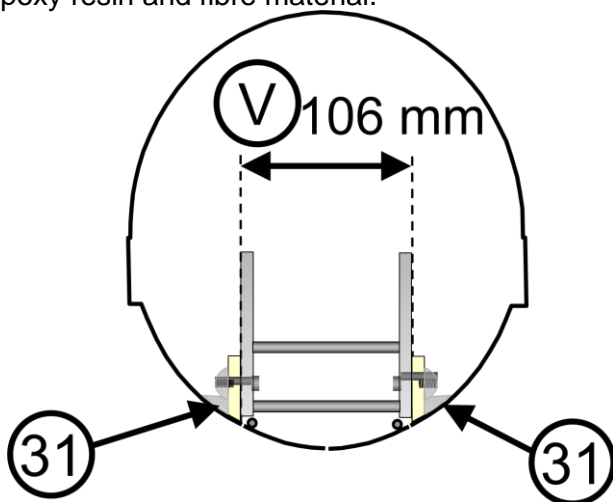

Graphic 1.10.4 Cross section of the fuselage upside down with the inserted aluminium support frame

## 1.11. Installation of the energy chain

A fastening element must be attached in the lower section of the fuselage ( see graphic 1.11.1 – 32 ). Use a cable strap to attach the last element of the energy chain.

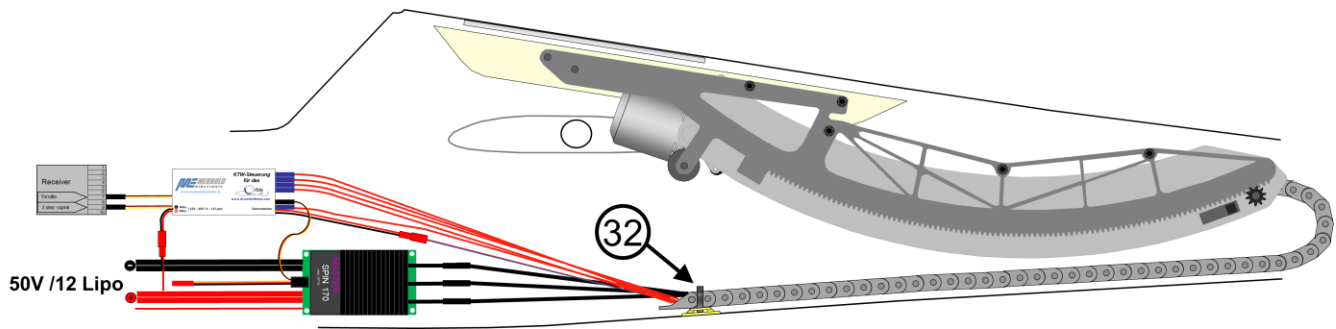

Graphic 1.11.1 Fastening of the energy chain in fuselages

## 1.12. Cabling for operation

In the condition as supplied to the customer the ORBIS 25 is already wired and all connectors are joined. It is only necessary to plug in the receiver, the brushless controller (MASTER SPIN 170 OPTO) and the lipo. Anyhow the entire cabling is shown in graphic 1.12.1 in case that an element has to be exchanged.

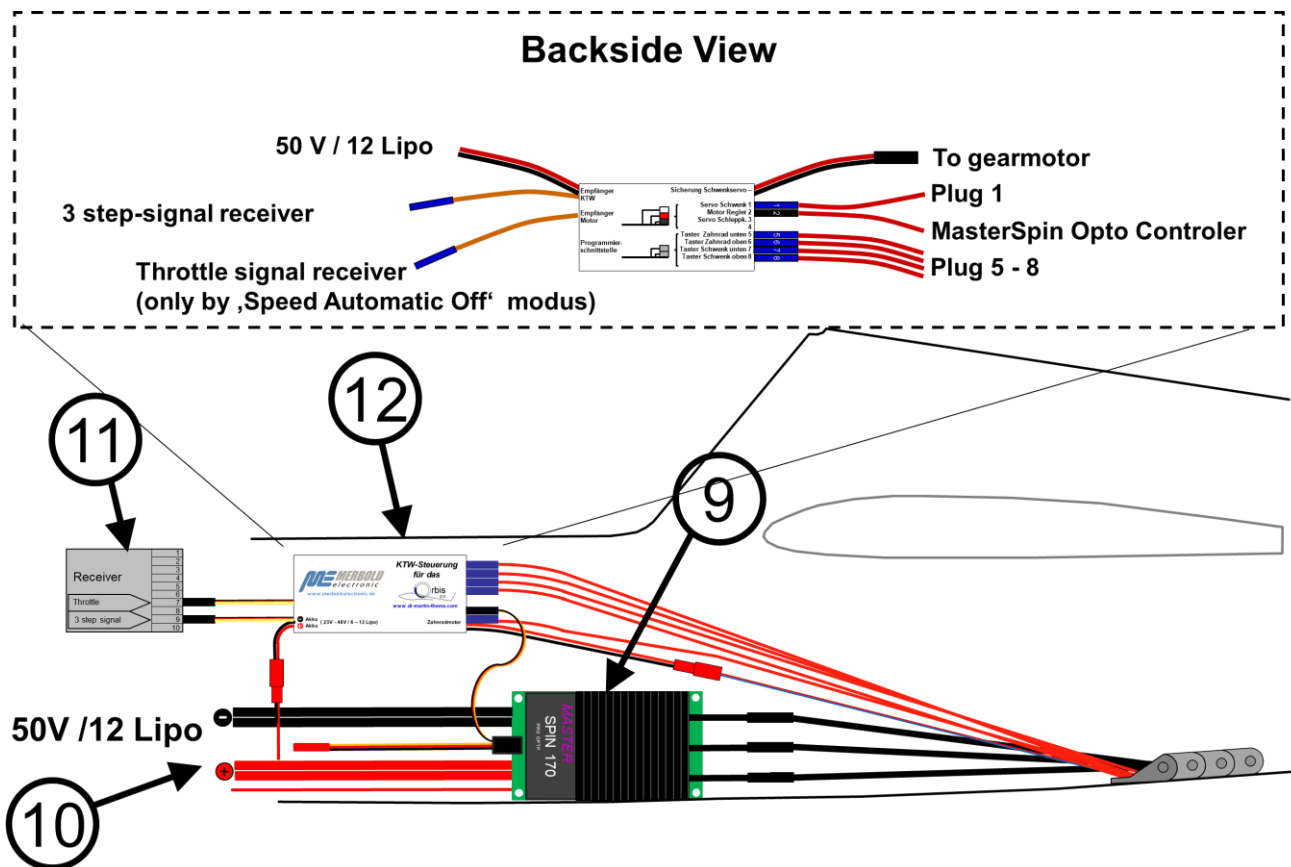

Graphic 1.12.-1 Cabling of the ORBIS 25 for operation

The female connectors coming out of the energy chain are numbered:

Connector 1: Servo cable for the tilt function.

On the socket 2 the black plug of the MASTER SPIN 170 OPTO is connected.

Connector 5: Connected to micro switch for the retraction deactivation of the gear motor.

Connector 6: Connected to micro switch for the extension deactivation of the gear motor.

Connector 7: Connected to micro switch for the retraction activation of the gear motor.

Connector 8: Connected to safety micro switch for the possible activation of the brushless motor.

### **1.13. Installation of the brushless motor**

When delivered, the Brushless Motor is already attached to the ORBIS 25. If replacement of the engine should be necessary, please note the following. The brushless motor is attached on the rotary plate with three M4 TORX countersunk screws of 14mm length. The motor cable must be routed through the CFK support and the energy chain.

### **1.14. Mounting of the prop mechanism**

The prop mechanism can be mounted by tightening both headless hexagon screws. The screws have to be positioned at both flat areas of the motor shaft. ( see graphic 1.15.1 – 33). Only this way the prop mechanism will hold on the motor shaft. The imbus screws are secured each with an additional hexagon screw and semi tight screw glue, so that the propmechanism will not loosen itself through vibration. This is the state in which the ORBIS 25 is delivered.



**Verify the fixing of the prop mechanism by trying to turn the prop mechanism while holding the motor crankcase.**

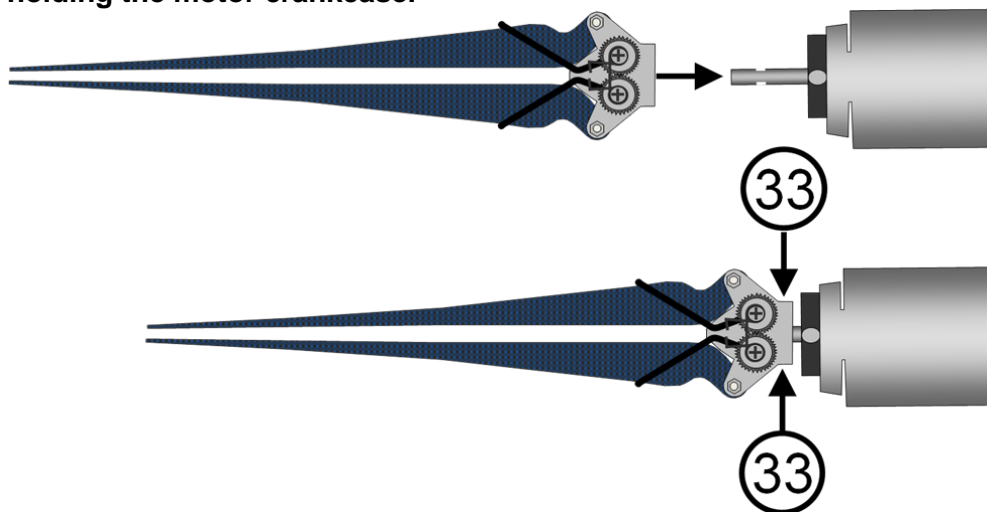

*Graphic 1.15.1 Mounting of the prop mechanism*



**Pay attention to the warnings for the prop mechanism in chapter 3.**

### **1.15. Installation of a fuselage cover**

The cast that was made in section 1.5. is now adapted to the form below. Be aware that you have to be able to extend and retract the ORBIS 25 to find the right position and form for the cover. The front edge ( 1.16.1-36 red line ) of the cover depends on the form of the fuselage. If the fuselage is narrow the cover must be smaller. Looking from the side the backrim of the cover ( 1.16.1-37) may not protrude the backside of the support arms.

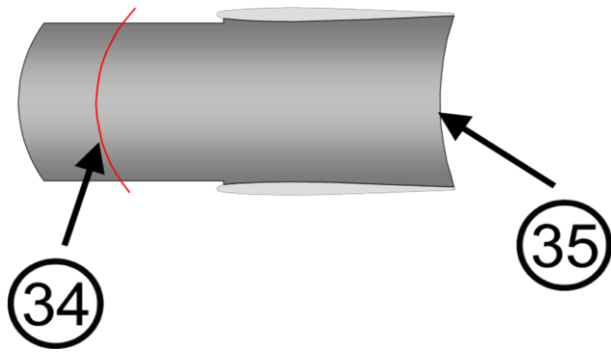

Graphic 1.16.1 Installation of a fuselage cover

Consider the curvature of the cover since the figure above is a top view. Do not glue the cover immediately between the ORBIS 25 support arms. Firstly attach the cover with adhesive tape and verify that the cover does not touch the fuselage wall or the levers of the end switches while the ORBIS 25 is retracting.

The cover must not collide with any parts in the fuselage. In the extended position the cover has to be flush with the rest of the fuselage wall. If the cover fits and has the correct form than attach it to the ORBIS 25 support arms with gel-superglue on the lower side of the cover.



**Pay attention that the rear edge of the cover ( see graphic 1.15.1 - 35) must flush with the rear edge of the support arms. If the cover is going beyond the edge, the ORBIS 25 cannot extend nor retract.**

### 1.16. Installation of springs and a piece of wood on the left fuselage hatch

Attach the spring on the M2 screw and hook the spring into the hook on the fuselage hatch (1.17.1 – 36).

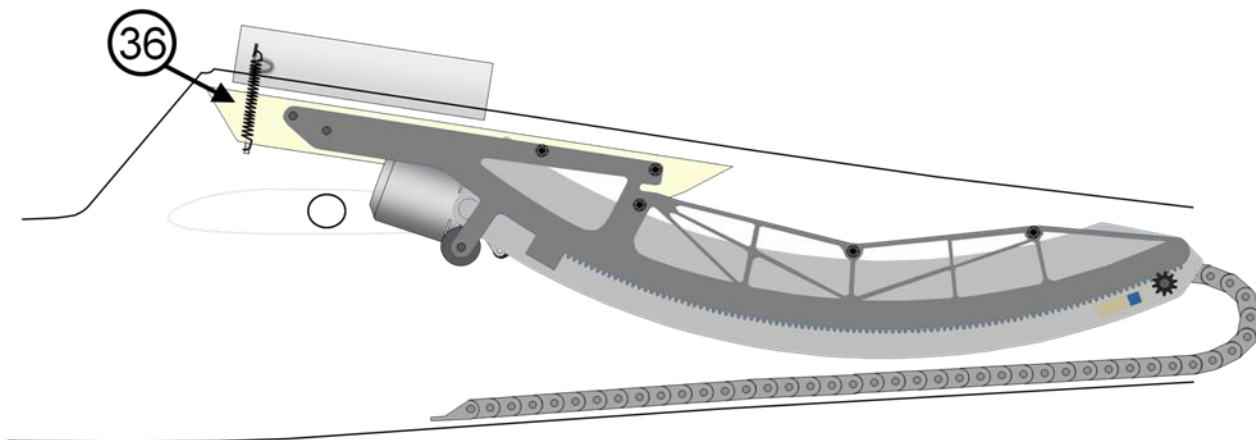

Graphic 1.17.1 Installation of springs on the fuselage hatches and a piece of wood on the left fuselage hatch

## 1.17. Installation of a wheel cover

It is recommended to shift the main wheel for 5 cm to the fuselage nose ( see graphic 1.18.1 – W). This will diminish the tendency of the fuselage to fall on the nose when performing a ground take-off. The wheel of the landing gear is to be provided with a wheel cover to avoid getting dirt inside the fuselage ( see graphic 1.18.1 – 40). The TRIAS retract from Thoma Modelltechnik UG offers such wheel covers and has two positions for landing and take-off.



**The interior of the fuselage and the ORBIS 25 must be protected against any contamination.**

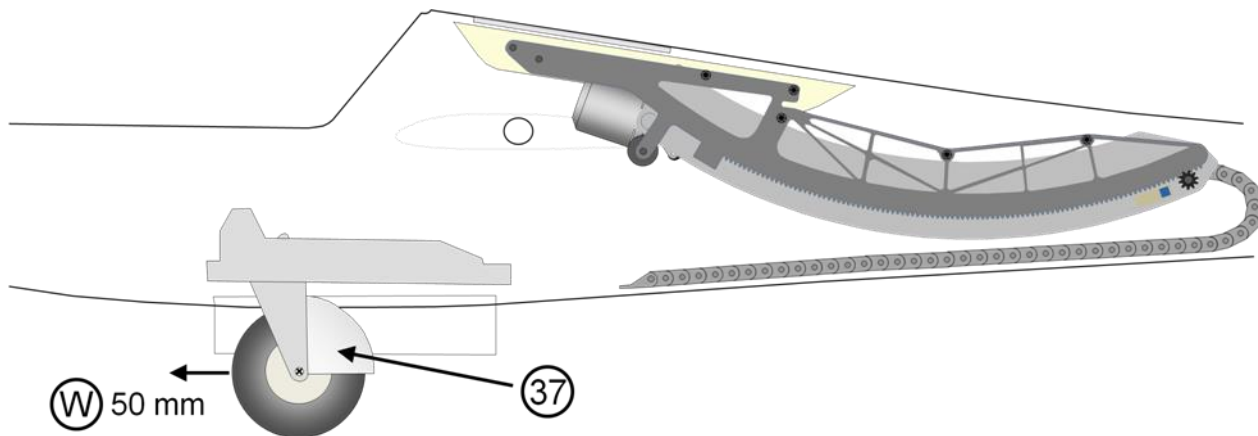

Graphic 1.18.1 Positioning of the main wheel and installation of a wheel cover

## 2. Warnings

### 2.1. General Attention

Before you operate a model airplane with motor power, you must be informed of the legal regulations in your country. A model airplane may legally be considered an aircraft and is subject to appropriate laws, which must be complied with.



**All models / modellers need to be insured. Check out insurance offerings of your national model organization. Never operate a model without insurance protection!**

Technical disturbances e.g. radio interferences are an incalculable risk and pilots are obliged to take all steps to avoid the possible damages. The minimum distance to populated areas, in order to ensure security for people, animals and buildings, must be at least 1.5 km. Keep safe distance from power lines. Do not fly the model in bad weather with low clouds or fog. Never fly directly into the sun. You could lose eye-contact with the model. In order to avoid collisions, you must land your model immediately, if a manned airplane approaches. The operation of a model with a self-launch-system under the influence of alcohol, drugs, medicines, etc. is absolutely forbidden. Operate only with best physical and mental condition. This is valid both for the operator and for its aides.

### 2.2. Warnings and safety instructions



#### General warnings

The operation of a self-launch-system can be very dangerous. The inappropriate operation of such a system, which transfers up to 4,2 KW power to the propellers, can cause substantial personal injury. This is a complex technology, which may be operated only by experienced model airplane pilots with at least 18 years of age. The operation of the self-launch-system requires a check list before each start and regular maintenance. The installation and operation of the self-launch-system may only be done according to these instructions. Before the launch of a model with this system you must check all functions and all rudders as well as the radio control range. Beyond that the instructions of the radio control are to be followed.



#### Clearance distance

People or animals must keep the following minimum distance to the model airplane with a running motor:

- in front of the motor 10 m
- to each side of the model 15 m
- behind the motor 1 m

Always hold the model at the rear end of the fuselage when you want to test the motor. Never hold the model at the front of the fuselage or from the side. These areas are in the danger zone.





### Range of application

The ORBIS 25 was solely developed for roll off ground by its own motor power. Other launch techniques are prohibited, in particular **hand launching** of the model airplane while the motor is running. This self-launch-system was solely designed for unmanned model airplanes. Do not use it for any other purpose, in particular for any manned aircraft.



### Prop mechanism

The tight mounting of the prop mechanism ( four hexagon socket screws and four M4 nuts ) and the motor (three M4 screws ) must be checked before each launch. All M4 nuts on the prop mechanism have to be secured with superglue. Otherwise the prop mechanism or motor can disassemble and injure people. From time to time you should clean the propellers with a moist piece of cloth.



### Vibrations

Should vibrations occur during operation, you will have to balance the prop mechanism and the motor bell again. The ORBIS 25 may not be operated with vibration under any circumstances, otherwise this may cause severe damage. If the vibration can not be eliminated, the ORBIS 25 must be sent to the Thoma Modelltechnik for maintenance.



### Propellers

The 25 x 12 " Freudenthaler propellers are specially designed and reinforced for the ORBIS 25. Only use these propellers which can be ordered on the website [www.dr-martin-thoma.com](http://www.dr-martin-thoma.com). Verify if the propellers are undamaged before each take-off. **Even the slightest damages on the propellers can cause severe damages to your body if parts of the propeller are released.** The entire prop mechanism must be balanced out after an exchange of the propellers ( see chapter 4 maintenance ). Clean the propellers with a moist cloth from time to time to remove e.g. residue of insects.



### Foreign parts

Any deviations from these instructions, like the use of other parts or materials and changes in the ORBIS 25 construction, affect the functionality of the system and must be avoided under all circumstances.



### Brushless controller

Use only the brushless controller MASTER SPIN 170 OPTO. This brushless controller is well established and harmonizes with the safety switch of the self-launch-system! Other brushless controllers could catch fire in the airplane and destroy your model.



### Dirk Merbold controller

The ORBIS 25 may only be operated with the controller of Dirk Merbold and the Thoma firmware version. The controller must be connected and programmed according to these instructions. Only the controller of Dirk Merbold permits a control over a 3-way-switch and thus provides the necessary security. In addition the controller accelerates the motor in the automatic modus very slowly thus preventing damages to the prop mechanism.



### **Operating**

The motor must never be started if the ORBIS 25 is not completely extended. Although the self-launch-system has a safety switch, it is possible that this switch can be damaged. This would allow the motor to start even if the ORBIS 25 is not completely extended. The starting of the motor in the fuselage would cause severe damage. Therefore it must always be verified by eye-contact before starting the motor (3-way-switch from centre to the front position) that the ORBIS 25 is completely extended and that the propellers are heading in flight direction. Before the ORBIS 25 is retracted it is to be verified by eye-contact that the propellers have come to a stop and pointing in the flight direction.



### **Indoor operating**

Never let the propellers run with full power indoors. Objects are hurled by the enormous air turbulence and could come into the propellers.



### **Foreign objects**

Never leave foreign objects ( e.g. pieces of cloth, screws, nuts) in the fuselage. This can lead to malfunctioning.



### **Dirt protection**

Protect the ORBIS 25 from dirt, rain and moisture. The prop mechanism is sensitive to dirt. Water might damage the electronic components. The wheel of the landing gear must have a wheel cover!

## **2.3. Disclaim of liability and damage**

The adherence to these installation, operating and maintenance instructions in connection with the model and the ORBIS 25 can not be supervised by Thoma Modelltechnik UG (limited liability). Therefore Thoma Modelltechnik UG (limited liability) does not accept any liability for loss, damages or costs, which may result from the incorrect operation, from incorrect behaviour and/or in any way coherently with the aforementioned.

The liability of the Thoma Modelltechnik UG (limited liability) for damages caused by the self-launch-system (including personal injuries, death, damage to buildings as well as damage by turnover or trading loss, by business interruption or other indirect or direct damages) is excluded, as far as German law does not regulate otherwise.

The liability is limited in all cases to the amount you paid for the self-launch-system.



**The model pilot takes the entire responsibility while operating the ORBIS 25. You affirm that Thoma Modelltechnik UG (limited liability) cannot supervise the adherence to these instructions concerning installation, operation, employment of airplane motor and employment of the radio control.**

On the part of Thoma model technology UG (limited liability) neither promises, contract arrangements, warranties nor other agreements were made to persons or companies concerning the functionality and the operation of the model. The operators rely on their own expertise and judgement with the acquisition of a model and/or this self-launch-system.

German law is applicable.

## 3. Programming and Operation

### 3.1. Introduction to the programming

The ORBIS 25 has four different operating modes. You must choose one and program this mode into the Dirk Merbold controller.

**Operating Mode 1 A:** 'Speed Automatic On' and 'tow release off' on the Merbold controller.

This is the **default and recommended mode** for several reasons:

- The 'Speed Automatic On' mode will always make sure that you have the right acceleration rate and will give you also the programmable power for ground take off.
- You will mainly fly with full throttle and thereby disburden the YGE brushless controller.
- The 'tow release off' mode gives you the opportunity to check the ORBIS 25 in the extended position without the motor starting to run.

**Operating Mode 1 B:** 'Speed Automatic Off' and 'tow release off' on the Merbold Controller.

**Operating Mode 2 A:** 'Speed Automatic On' and 'tow release on' on the Merbold Controller.

**Operating Mode 2 B:** 'Speed Automatic Off' and 'tow release on' on the Merbold Controller.

### 3.2. Programming of the radio transmitter

For all operation modes the ORBIS 25 needs a **3-way-switch** which is assigned to a separate channel on the radio transmitter. In the "Speed Automatic On' you will actually only need the **3-way-switch** to control the entire ORBIS 25.

The 3-way-switch has pre-defined values for each switch position.

These values are reached, when the **3-way-switch** switches the appropriate channel to the following servo positions:

- 100% with position 1 (back)	1100 µs impulse length
0% with position 2 (centre)	1500 µs impulse length
+100% with position 3 (in front)	1900 µs impulse length



#### **Important note for Jeti systems**

Please make the servo pulse length of the Jetisystem or PowerBox is set to 20ms. A smaller or larger pulse length may results in malfunction of the Merbold controller.

In the 'Speed Automatic Off' mode you will need a **second continuous channel** for the throttle signal.

The three defined operating settings in the **'tow release off' modus** are:

- Position 1 (back): ORBIS 25 retracted & motor off for gliding.
- Position 2 (centre): ORBIS 25 extended & motor off .

- Position 3 (in front): ORBIS 25 extended & motor slowly accelerating in the 'Automatic throttle control' operation mode or ready for the manual throttle signal.

The three defined operating settings in the '**tow release on**' **modus** are:

- Position 1 (back): Tow release locked & ORBIS 25 retracted & motor off for gliding.
- Position 2 (centre): Tow release unlocked & v retracted & motor off for gliding.
- Position 3 (in front): ORBIS 25 extended & motor on for the motorized climb or ready for the manual throttle signal after extension.

The three operating conditions of the **3-way-switch** must correspond to certain servo positions, since the Merbold controller switches on two predefined signal values:

- Switch from position 1 to position 2 at 1300  $\mu$ s receiver pulse length.
- Switch from position 2 to position 3 at 1700 ms receiver pulse length .

### 3.3. *Programming of the receiver*



**Important note for the receiver: Set the output period to 20ms**

Modern receivers allow a shorter output period than 20ms. Unfortunately, the Merbold control can't convert the receiver signals correctly if the output period is less than 18ms. Please set the receiver's output period to 20ms.

The **fail-safe adjustment** has to be the following:



The receiver fail-safe adjustment for the **3-way-switch** channel must be put on '**hold the last valid signal**' on the receiver. This assures that the last valid operation condition of the ORBIS 25 and that no unexpected behaviour happens.

The receiver fail-safe adjustment for the **elevator** signal channel must be also put on '**hold the last valid signal**' on the receiver. This assures that the last valid signal for the elevator remains. This is important when the ORBIS 25 is running because you will need a different elevator adjustment.

The receiver fail-safe adjustment for the **flaps and retract** channel must be also put on '**hold the last valid signal**' on the receiver.

The **side rudder** and the **ailerons** must fail safe in **neutral position**.

### 3.4. *Installation and adjustment of the MASTER SPIN 170 OPTO controller*



The MASTER SPIN 170 OPTO controller is always connected to the male connector 2 of the Merbold Controller. This is also the case when you want to use the 'Speed Automatic Off' mode where you want to control the throttle manually. Otherwise you loose all safety functions!





For safety reasons the ORBIS 25 may only be operated with the MASTER SPIN 170 OPTO controller. It has special parameters that supports the safety functions. The use of other controllers can lead to serious damages.

The preprogrammed MASTER SPIN 170 OPTO controller is available on the website: [www.dr-martin-thoma.com](http://www.dr-martin-thoma.com)

The MASTER SPIN 170 OPTO controller is programmed with the following parameters that harmonize with the ORBIS 25 Merbold Controller. The programming is possible via the JetiBox.

The ORBIS 25 with MASTER SPIN 170 OPTO is operated with 12s lipo. The resulting power is app. 4.200 Watt depending on the quality of the used lipos. The ORBIS 25 is suitable for RC gliders with 25kg – 50kg weight.

Ebene: Man Settings		
Parameter	Value	Description
Temp Protection	105°C	Parameter for temperature protection
Brake	HARD 70/100/0,5s	 Keep this value to ensure braking of propellers.
Operation Mode	NORMAL	Normal Mode for planes
Timing	18°	
Frequency	8 KHz	
Acceleration	0-100% 4s	 Keep this value to ensure slow acceleration of propellers.
Acumulator type	Li-Ion/Pol/Fe	
Number of cells	AUTO	Automatic recognition of number of lipo cells.
Li-XX Cut Off	V per cell 2,7V	Power is cut off when the voltage per cell is beneath 2,7V.
Off Voltage Set	<35V	
Cut Off	Slow Down	
Initial Point	FIX	Fixed point for throttle signal
Fix Initial Point	1,17ms	This initial point is adjusted to the Merbold Controller.
End Point	1,80ms	This end point is adjusted to the Merbold Controller.
Auto Inc End Point	ON from 1,80ms	Automatic adjustment of the end point if the 1,80ms are exceeded.
Throttle Curve	Linear	
Rotation	RIGHT	
Start Power	Auto -20%	 This value also ensures a slow acceleration of the props and prevents damages on the props. <b>Don't change this value!</b>
Setting th. R/C	OFF	

### 3.5. Introduction to the Dirk Merbold controller



**The ORBIS 25 may only be operated with the Dirk Merbold controller!**

These are the features of the Dirk Merbold controller:

- Full automatic mode of the ORBIS 25 with one 3-way-switch.
  - ⇒ slow, programmable acceleration of the motor.
  - ⇒ slow deceleration of the motor. (ca. 3s)
  - ⇒ Motor kill for take-off disruption.
  - ⇒ Programmable motor start power and latency time for the first acceleration.
  - ⇒ From the second acceleration, the motor will accelerate to full power without latency time.
- Mode for manual operation of throttle signal (Speed Automatic Off )
  - ⇒ Perpetuation of the safety functions
  - ⇒ only in the fully extended position the manual throttle signal will get to the Jeti MASTER SPIN 170 OPTO brushless controller. In all other ORBIS 25 positions the manual signal is capped and replaced by a 'zero motor power' signal.
  - ⇒ the retraction of the ORBIS 25 with running motor is prevented.
- Full control of the gear motor for the extensions and retraction of the ORBIS 25. The gear motor is supplied with power from the main motor lipo.
- Full control of the HiTec turning servo in the ORBIS 25.
- Option to control the tow-release with the 3-way-switch.

### 3.6. Programming of the Dirk Merbold controller

The cabling for operation was already shown in chapter 1.12.



**For safety reasons connect a test servo on the male connector 2 of the Dirk Merbold controller or have the motor lipo for the MASTER SPIN 170 OPTO controller disconnected. This way you can verify the programmed values without having the risk that the motor starts running. Never program with a MASTER SPIN 170 OPTO controller which is ready to run!**

Graphic 3.6.1 displays the cabling of the Dirk Merbold controller for the programming.

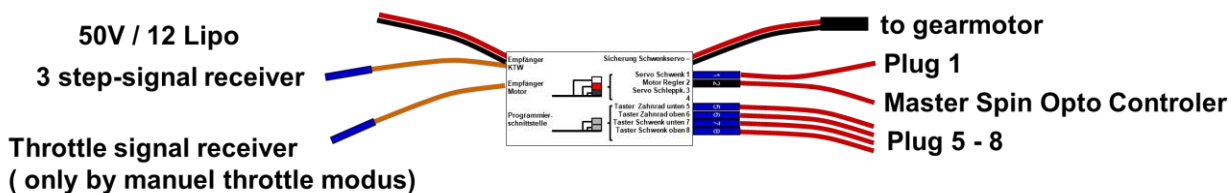

Graphic 3.6.1 Cabling of the Dirk Merbold controller for programming.

Do the following to start programming:

1. Turn the transmitter on. 3-way-switch on rear position –100% 1,1 µs pulse length.
2. Attach the motor lipo.
3. Turn the receiver on.
4. Connect the programming module with the large display
5. 3-way-switch on middle position 0% ( 1500 µs pulse length). Orbis will extract and is now in position to be programmed.

The display will first show ‚Merbold Electronic‘ and the hardware version. The controller parameters will be read out and afterwards the software version ‚Dr.Thoma‘ must be seen. After ~ 2 seconds you will reach the selection menu.



The programming module is now ready.



The programming module has a rotary knob which also can be pushed. By rotating you pass through the menu in level 1, 2 or the parameters. By pushing the knob you select the menu or you save the parameters. The values are always effective immediately with one exception: the language change ( Deutsch/English). You will have to disconnect the programming module and reconnect.

The programming menu is the following:

The **green menu** may be changed.

The **red menu** may **not** be changed.

Programming Menu			
1. Selection Level	2. Selection Level	Default Value	Description
<b>Turning Servo</b>			
	Deadtime Arm In	Deadtime Arm In: 5s	Selection: 0s to 9s  <b>Do not reduce the value below 5 seconds. Otherwise the propellers will still turn, when the ORBIS retracts.</b>
	Arm In Pos	Arm In Pos : ~ 001%	Selection: 0% to 100%
	Arm Out Pos	Arm Out Pos : ~100%	Selection: 0% to 100%
	Arm centre Pos	Arm centre Pos: 098%	Selection: 0% to 100% This is the position the servo takes if there is a defect on the switch.
	Arm speed I-O	Arm speed I-O: 90%	Selection: 0% to 100%
	Arm speed O-C	Arm speed O-C:90%	Selection: 0% to 100%
	Arm speed C-I	Arm speed C-I: 90%	Selection: 0% to 100%
	Back		
<b>No Doors</b>			
			Not relevant for the ORBIS
<b>Motor</b>			
	Motor Stop	Motor Stop: 017%	Selection: 0% to 100%. The value when the motor stops.
	Auto On/Off	Speed Automatic On	Selection: On / Off  <b>This is the selection between operating mode A or B (see chapter 3.1)</b>

	<b>Speed minimum</b>	Motor Start: 087%	Selection: 0% to 100%
	<b>Latency Time</b>	Latency Time: 2s	Selection: 0s to 9s
	<b>Speed maximum</b>	Motor Max: 087%	 <b>Do not change this value. It corresponds to 100% full throttle for the MASTER SPIN 170 OPTO ( 1.900 µs )</b>
	<b>Slow Function</b>	Slow Function: 40%	40% -> 6 seconds 100% -> 12 seconds Only relevant by acceleration.  <b>Don't go below 40%.</b>
	<b>Init Controller</b>	Init Controller: No	Selection: No / Yes
	<b>Back</b>		
<b>Tow Release</b>			
	<b>Release Open</b>	Release max 100%	Selection: 0% to 100%
	<b>Release Closed</b>	Release min 0%	Selection: 0% to 100%
	<b>Back</b>		
<b>Setup</b>			
	<b>Receiver Monitor</b>	Adjust to RC: No	Selection: No / Yes RC Signal is displayed from Input 'Empfänger KTW'
	<b>Reset all</b>	No	Selection: No / Yes If you want to reset to initial parameters
	<b>Language</b>	Deutsch	Selection: Deutsch/English Programmer has to be disconnected and reconnected to activate new language.
	<b>Mode</b>	Tow release off	Auswahl: On / Off  <b>This is the selection between operating mode 1 or 2 (see chapter 3.1)</b>
	<b>Back</b>		
<b>Servotester</b>			
	<b>Servotest CH1</b>		Generates a servosignal on CH1
	<b>Servotest CH2</b>		Generates a servosignal on CH2
	<b>Back</b>		
<b>Measure Pulses</b>			
	<b>Measure Pulse CH1: XXXX µs</b>		Measures the pulse on CH1
	<b>Measure Pulse CH2: XXXX µs</b>		Measures the pulse on CH2
	<b>Back</b>		



In case you use the 'Speed Automatic On' mode the parameters have the following impact on the power-time curve:

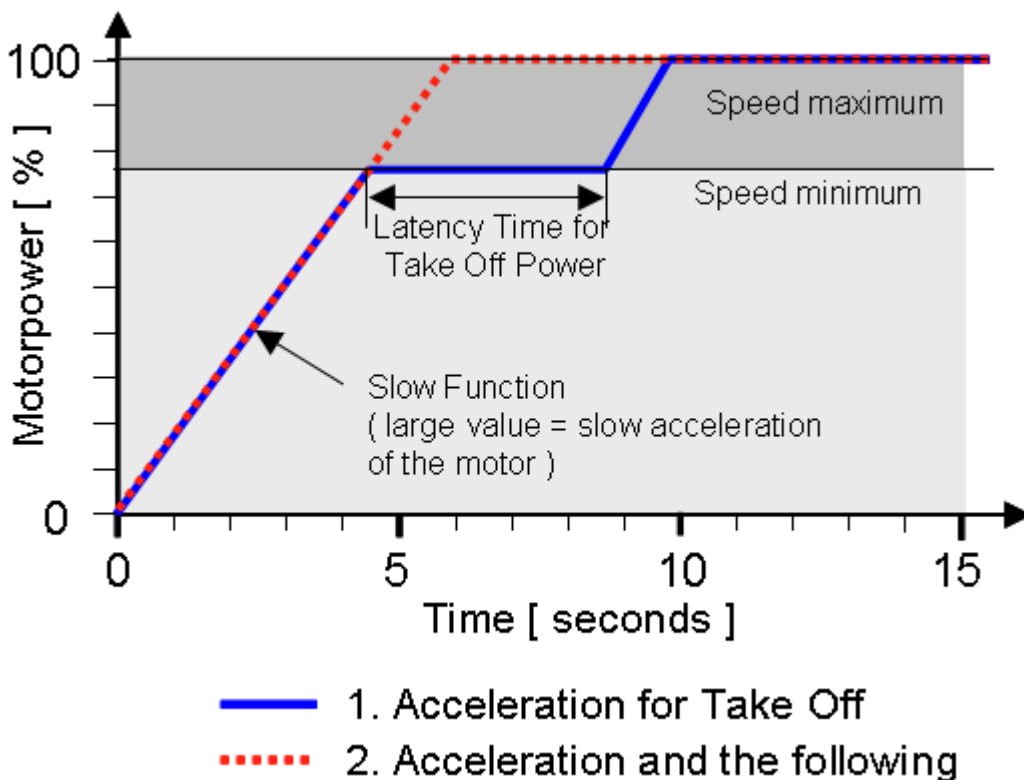

Grafik 3.6.2 Display of the parameters for the 'Speed Automatic On' Mode

### 3.7. Operation procedure

The operation procedure is as follows:

#### 3.7.1 Examination of the model airplane and of the ORBIS 25

- Before the first flight of the day you must verify if all screws are fastened and that the prop mechanism is secured tightly on the motor shaft. Hold the prop mechanism and try to turn the motor back and forth. If the prop mechanism is loose tighten the hexagon screws ( see graphic 4.1.-1-33 ).
- Are there any foreign objects in the fuselage? Are all components fastened in the fuselage?
- Are the receiver and radio transmitter batteries fully charged?
- Is the motor battery fully charged?

3.7.2 Turn on the radio control and check to make sure the 3-way-switch has to be in the rear position for the operating mode 1 and 2 ( see chapter 3.1 ). The ORBIS 25 must be retracted. Also possible is the middle position of the 3-way-switch. But the ORBIS 25 must be fully extended in the operating mode 1. The turning servo (15) must always be on an end position to have a defined start parameter.

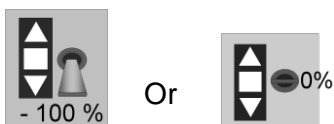



3.7.3 The power for the receiver is turned on.





3.7.4 The battery for the motor is connected.

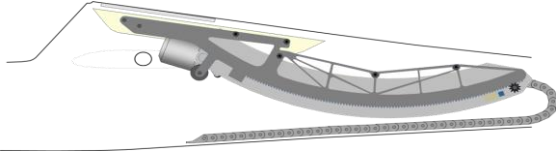
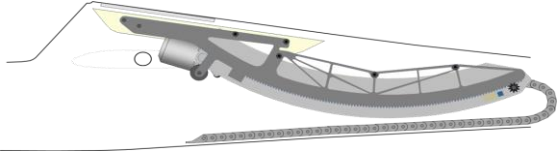
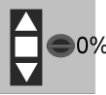
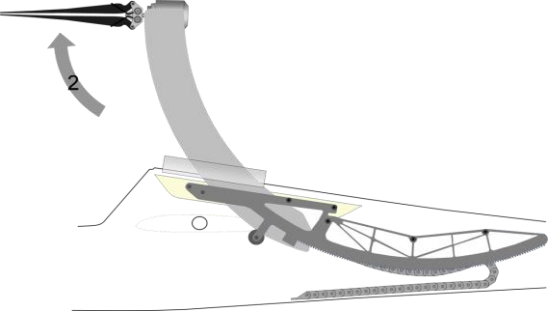
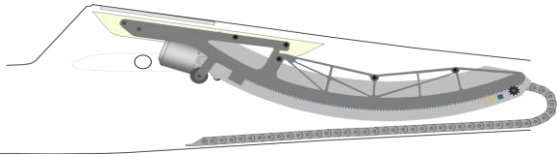

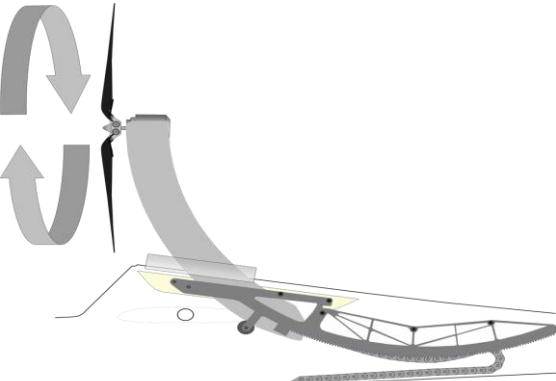
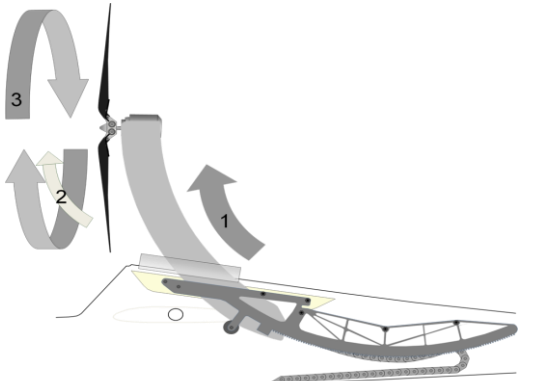

3.7.5 A test of all rudders is performed. Is the movement of the radio control sticks corresponding to the movement of the rudders?

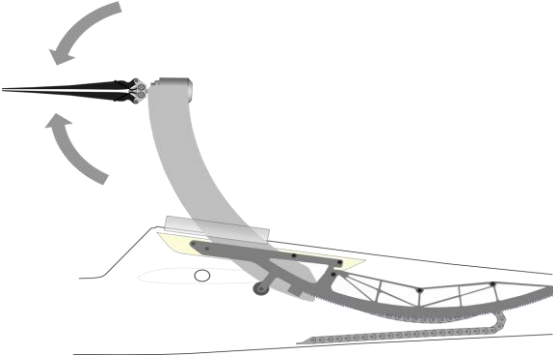
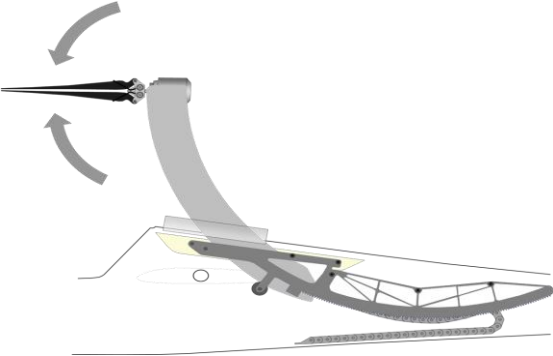
3.7.6 A radio control range test is performed.

3.7.7 When the 3-way-switch is in the rear position ( -100% ) the ORBIS 25 is retracted. Depending on the operating mode ( see chapter 3.1 ) the ORBIS 25 will be conduct the following steps when the 3-way-switch is operated.

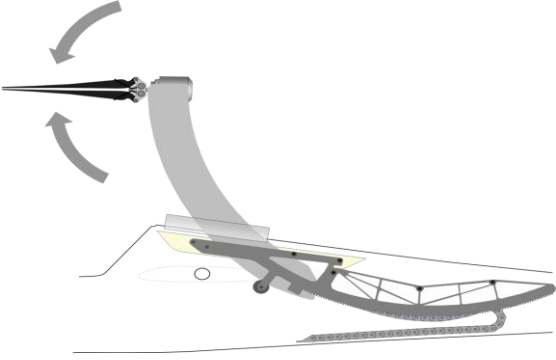
3-way-switch	Operating Mode 1 ( Tow release off )	Operating Mode 2 ( Tow release on )
		 Tow release closed.
	 ORBIS 25 extracts and turns the propellers in flight direction.	 Tow release open.
	 The motor will start slowly in the 'Speed Automatic On' mode A In the 'Speed Automatic Off' mode B you can give the throttle signal manually.	 ORBIS 25 extracts and turns the propellers in flight direction. The motor will start slowly in the 'Speed Automatic On' mode A In the 'Speed Automatic Off' mode B you can give the throttle signal manually.

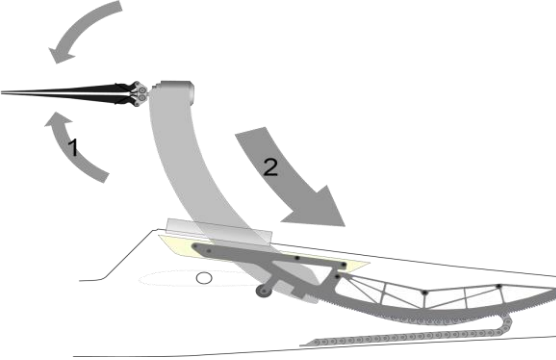
3-way-switch	Operating Mode 1 ( Tow release off )	Operating Mode 2 ( Tow release on )
	<p>It is important to operate the ORBIS in intervals in order to avoid overheating. The intervals are as follows:</p> <p><b>1,5 minutes runtime</b>  <b>20 minutes cooling time</b>  <b>1,5 minutes runtime</b>  <b>20 minutes cooling time</b>  <b>etc</b></p> <p>It is advisable not to immediately retract the ORBIS engine after each runtime phase so that the engine can still cool down in the air flow for 1 minute. This is only possible in the preferred operating modes 1A and 1B 'tow release off'.</p>	<p>It is important to operate the ORBIS in intervals in order to avoid overheating. The intervals are as follows:</p> <p><b>1,5 minutes runtime</b>  <b>20 minutes cooling time</b>  <b>1,5 minutes runtime</b>  <b>20 minutes cooling time</b>  <b>etc</b></p> <p>It is advisable not to immediately retract the ORBIS engine after each runtime phase so that the engine can still cool down in the air flow for 1 minute. This is only possible in the preferred operating modes 1A and 1B 'tow release off'.</p>
 <p><b>Motor kill before speed maximum is reached</b></p> 	<p>If you interrupt the <b>first acceleration</b> before the speed maximum is reached, the motor will be braked fast. The ORBIS 25 will remain in this position with braked motor.</p>  <p>The Dirk Merbold controller can only be rested by turning off the power supply of the receiver and turning on again. This is safety feature when the take off is interrupted.</p> <p>By the second and the following accelerations this feature is not activated.</p>	<p>If you interrupt the <b>first acceleration</b> before the speed maximum is reached, the motor will be braked fast. The ORBIS 25 will remain in this position with braked motor.</p>  <p>The Dirk Merbold controller can only be rested by turning off the power supply of the receiver and turning on again. This is safety feature when the take off is interrupted.</p> <p>By the second and the following accelerations this feature is not activated.</p>
	<p>The motor decelerates in ~ 3 seconds. The ORBIS 25 remains extended.</p>	<p>The motor decelerates in ~ 3 seconds. The ORBIS 25 remains extended for further 5 seconds (parameter: Deadtime Arm In!) and will afterwards retract automatically.</p>

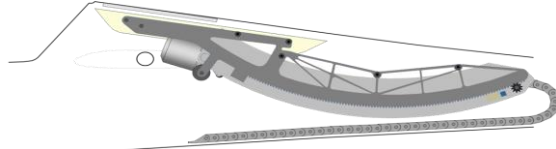
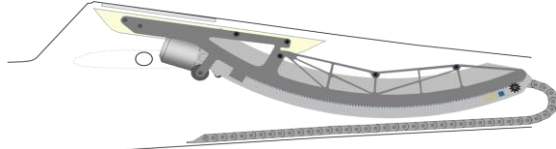
3-way-switch	Operating Mode 1 ( Tow release off )	Operating Mode 2 ( Tow release on )
	 <p> Slow down the aircraft to under 60 km/h ( 40 mph ) so that the prop mechanism can fold the propellers in flight direction.</p>	 <p> Slow down the aircraft to under 60 km/h ( 40 mph ) so that the prop mechanism can fold the propellers in flight direction.</p>
	 <p>This is the landing position and position for turning off the receiver. In the 'Speed Automatic Off' mode B you must turn down the throttle signal manually to -100% ( zero power ). For safety reasons the manual throttle signal will remain capped while retracted. Never leave or transport the model airplane with extended ORBIS 25.</p>	 <p>Tow release closed. This is the landing position and position for turning off the receiver. In the 'Speed Automatic Off' mode B you must turn down the throttle signal manually to -100% ( zero power ). For safety reasons the manual throttle signal will remain capped while retracted. Never leave or transport the model airplane with extended ORBIS 25.</p>

3.7.8 The battery for the motor is disconnected.

3.7.9 The power for the receiver is turned off.

3.7.10 The power for the radio control is turned off.

### 3.8. *During operation: avoiding overheating of the motor*

To prevent the motor from overheating, only interval operation of the ORBIS is permitted. The intervals are as follows:

1.5 minutes running time under full load  
20 minute cool down time with engine off  
1.5 minutes running time under full load  
20 minute cool down time with engine off  
etc.

It is advisable not to run in the engine after each runtime phase so that the engine can still cool down in the air flow for 1 minute. This is only possible in the preferred operating modes 1A and 1B 'tow release off'.

**Note:** The external rotor motors have an efficiency of approx. 85-90%. This means that with an effective power of 3000 watts, approx. 300 - 400 watts of heat output is generated in the motor. A soldering iron has a heat output of 60 to 100 watts and easily reaches 200°C in 2 minutes.

## 4. Maintenance

### 4.1. Prop mechanism and motor bell

The prop mechanism may not be modified from his original configuration. Do not attach or detach any nuts or any other parts!



When delivered, the prop mechanism and the motor bell is always balanced. It is important that the prop mechanism is mounted in the same position on the motor shaft again. The position of the prop mechanism is therefore to be marked with a felt pen on the motor shaft and the prop mechanism **before removing**.



Before the first flight of the day you must verify if the prop mechanism is secured tightly on the motor shaft. Hold the prop mechanism and try to turn the motor back and forth. If the prop mechanism is loose tighten the hexagon screws ( see graphic 4.1.-1-33 ). Be aware that the hexagon screws are secured by a second hexagon screw, which must be removed first.

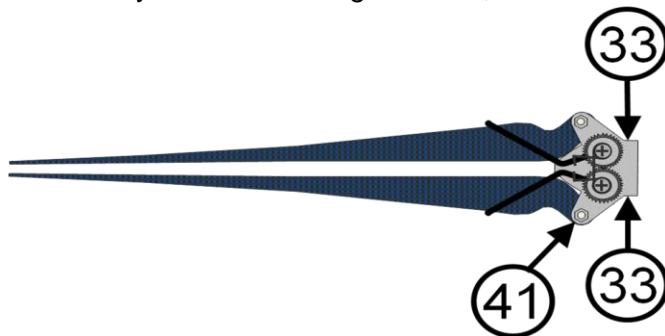

Graphic 4.1.-1 Prop mechanism

If you need to replace the propellers, then remove the steel M4 nut and pull out the 4 mm bolt ( see graphic 4.1.-1-41 ) . Use only the following propellers:  
25" x 12" Reinforced Freudenthaler Carbon Props to be ordered on [www.dr-martin-thoma.com](http://www.dr-martin-thoma.com)  
After mounting the propellers fasten the steel M4 nuts tightly and secure them with superglue. The propellers must still be able to turn easily.

## Adjusting and balancing of the prop mechanism

After each change of propellers the prop mechanism has to be well balanced. Use a calliper to hang out the spring clips on the wire bow ( see graphic 4.1.-2 -42 ).

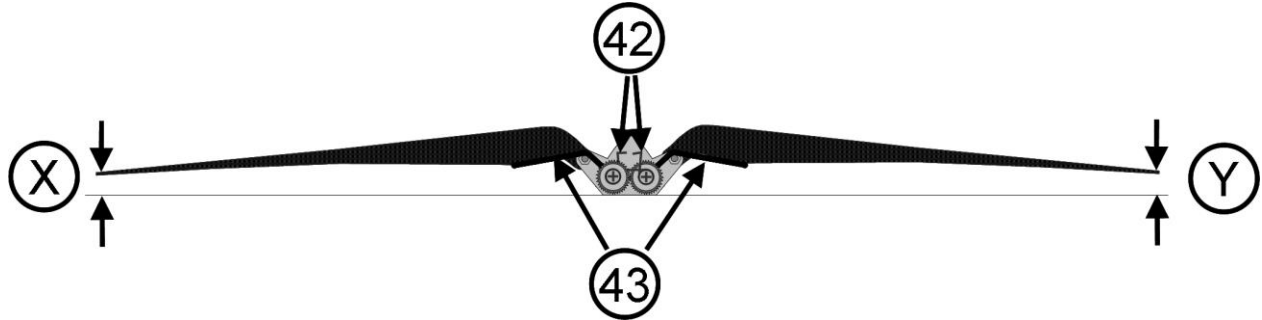

Graphic 4.1.-2 Adjusting the distances

Lay the prop mechanism on a plain surface ( e.g. a glass table ) and control the distances X and Y. These distances have to be equal with an accuracy of 0,2 mm. If these distances should differ by more than 0,2 mm than adjust the wire bows ( see graphic 4.1.-2 -43 ). with a collet. Afterwards you use a custom balancer e.g. from TopFlite ( <http://www.top-flite.com>) to balance the prop mechanism in the unfolded condition. If you need to replace the spring secure the steel M4 screws with superglue after having replaced the spring.



**If you do not secure all M4 nuts with superglue the prop mechanism might lose parts. This could lead to severe damage and injuries.**

Keep the prop mechanism clean because it is sensitive to dirt. Dirt could jam the gear wheels. This is a main reason why dirt must not get into the fuselage. Lubricate the gear wheels with gear oil once a year.

## Dynamic balancing

After mounting the prop mechanism on the motor axis with the 4 socket head screws, regulate carefully the throttle in the extended state via an additional servo tester on the MASTER SPIN 170 OPTO controller. Once a vibration occurs, immediately reduce the throttle via the servo tester. Now a thick scotch tape is mounted on the upper surface of the propeller and then accelerate again. If the vibration is getting less then grind on the opposite propeller on the bottom with fine sandpaper until the scotch tape is unnecessary. If the 'scotch tape process' does not lead to a satisfactory smoothness, a small M4 hexagon screw must be screwed into the rear engine bell (see chart 4.1.-3). Then accelerate again and test whether the vibration is still present. Change the location and number of bolts until the vibrations have disappeared in all speed ranges. Use screw glue to secure the M4 hexagon screw.

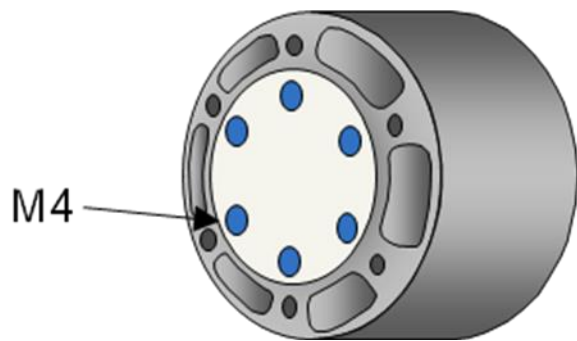

Graphic 4.1.-3 The motor bell of the brushless motor with the M4 holes

### Operation

When you use the prop mechanism the first time, accelerate slowly and check for vibrations. If the prop mechanism vibrates than adjust the distances X and Y and balance the prop mechanism again.



**The motor may not vibrate when the props accelerate. This may lead to a damage of the gear motor and of the plane! Stop the motor immediately!**

Should vibrations occur during operation, you will have to balance the prop mechanism and the motor bell again. The ORBIS 25 may not be operated with vibration under any circumstances, otherwise this may cause severe damage. If the vibration cannot be eliminated, the ORBIS 25 must be sent to the Thoma Modelltechnik UG for maintenance.

## 4.2. Self-launch-system

### Gearwheel



Verify regularly if the headless screw in the gear wheel is fastened and secured with superglue (4.2.-1 40), otherwise the plane can be severely damaged.

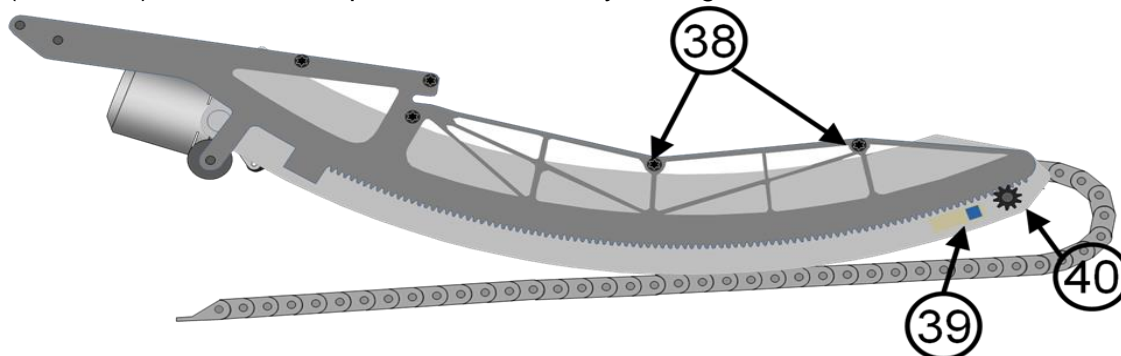

Graphic 4.2.-1 Gearwheel and limit stop for the rollerlevel micro switch

### Micro switches and cabling

Inspect the micro switches regularly (Graphic 1.1.2 - 16 to19), especially the safety switch (Graphic 1.1.2 - 16 ). Also check the cabling and the female connectors for damages. The ORBIS will not function correctly otherwise and the gear motor will be damaged.

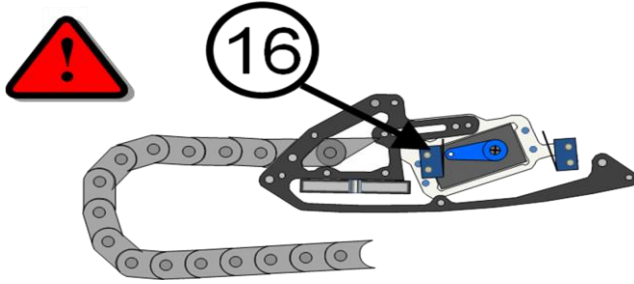

*Graphic 4.2.-3 Micro switch*

### **Aluminium rails and spur gear**

Keep both aluminium rails and the spur gear clean and lubricate them with lubricating grease once a year. Do not use an oil spray since oil could get on the micro switches. This could lead to malfunction.

### **Screws**

Inspect the screws of the ORBIS 25 regularly. Through vibration the screws can loosen themselves. This is especially important for the screws in the motor area.

## **5. Warranty**

The warranty comprises the free repair and/or the replacement of such parts, which exhibit proven productions or material defects during the guarantee period starting from the date of the purchase. Further liability claims are not admissible. Transportation, packing and shipment costs are paid by the buyer. For transport damages no liability is taken over. Send along an error description and the bill with the purchase date to Thoma Modelltechnik UG (limited liability). The warranty is void, if the damage of the ORBIS 25 self-launch-system or the model is due to an accident, inappropriate handling or wrong use.